

Baoli

KBP 15L



Baoli

1.1	Manufacturer		KION BAOLI
1.2	Manufacturer's type designation		KBP 15L
1.3	Drive: electric, diesel, petrol, fuel gas		Electric
1.4	Operator type: hand, pedestrian, standing, seated, order-picker		Pedestrian
1.5	Rated capacity / Rated load	Q (t)	1.5
1.6	Load centre distance	c (mm)	600
1.8	Load distance, centre of drive axle to fork	x (mm)	940/875
1.9	Wheelbase	y (mm)	1200/1135
2.1	Service weight	Kg	160
2.2	Axle loading, laden front/rear	Kg	510/1140
2.3	Axle loading, unladen front/rear	Kg	130/30
3.1	Tyres: solid rubber, superelastic, pneumatic, polyurethane		PU
3.2	Tyre size, front		Ø 210x70
3.3	Tyre size, rear		Ø 80x61 / Ø 78x88
3.4	Additional wheels (dimensions)		-
3.5	Wheels, number front/rear (x = driven wheels)		1x/4 / 1x/2
3.6	Tread, front	b10 (mm)	-
3.7	Tread, rear	b11 (mm)	390 / 535
4.4	Lift	h3 (mm)	115
4.9	Height drawbar in driving position min/max	h14 (mm)	700/1260
4.15	Height, lowered	h13 (mm)	80
4.19	Overall length	l1 (mm)	1550
4.20	Length to face of forks	l2 (mm)	400
4.21	Overall width	b1/b2 (mm)	616/720
4.22	Fork dimensions ISO 2331	s/e/l (mm)	50x150x1150
4.25	Distance between fork-arms	b5 (mm)	540/685
4.32	Ground clearance, centre of wheelbase	m2 (mm)	30
4.34.1	Aisle width for pallets 1000 x 1200 crossways	Ast (mm)	2146
4.34.2	Aisle width for pallets 800 x 1200 lengthways	Ast (mm)	2094
4.35	Turning radius	Wa (mm)	1330
5.1	Travel speed, laden/unladen	km/h	4,5/5
5.2	Lift speed, laden/unladen	m/s	0,028/0,031
5.3	Lowering speed, laden/unladen	m/s	0,068/0,043
5.8	Max gradeability, laden/unladen	%	6/16
5.10	Service brake		Electromagnetic
6.1	Drive motor rating S2 60 min	kW	0.75
6.2	Lift motor rating at S3 15%	kW	0.8
6.3	Battery according to DIN 43531/35/36 A, B, C, no		-
6.4	Battery voltage/nominal capacity K5	V/Ah	24/30
6.5	Battery weight	kg	8
6.6	Energy consumption according to VDI cycle	kWh/h	-
8.1	Type of drive unit		DC
10.7	Sound pressure level at driver's seat	dB (A)	<74

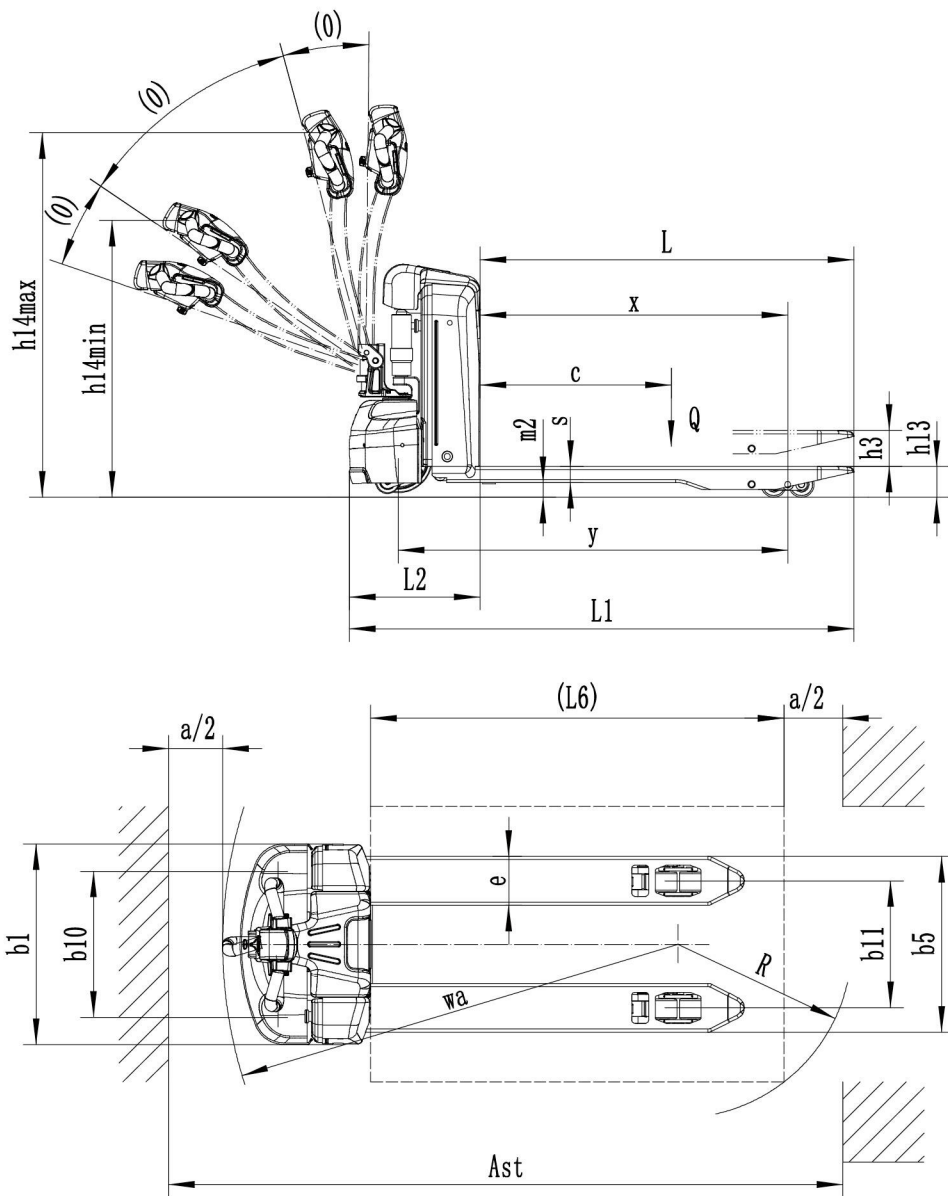

KBP 15L



The KBP 15L, with a load capacity of 1.500 kg and its compact size of only 400 mm to face of forks, is the Baoli pallet truck for any medium duty application in warehouses, logistics and industry.

Solidly manufactured trucks are the basis of the Baoli company's success, and the KBP 15L, thanks to its very robust chassis and the reliable components, confirms it. The long tiller arm provides optimal and highly ergonomic control of the vehicle with right or left hand, requiring less operating force and allowing the driver to keep an optimal distance from the vehicle.

KBP 15L is offered with a 24 Volt / 30 Ah lithium-ion battery and with an onboard charger: this allows higher

truck availability, due to easy intermediate charging at any standard power outlet. The battery offers around 4 hours of operation, and it will be possible to tackle an entire work cycle by exploiting the interim charges offered by lithium technology. It's possible to order the truck with a second spare battery and an external charger; that further increases truck availability.

Options for different forks lengths and widths, the turtle button for operation in narrow spaces, and very good performances on slopes complete the features of the KBP 15L guaranteeing a very high efficiency in any condition. Finding the perfect pallet truck for any type of usage has never been so an Easy Choice.

Technology and features

- ✓ Small size (l2=400 mm) and low service weight (160 kg)
- ✓ 24 Volt / 30 Ah removable lithium-ion battery
- ✓ Easy charging due to onboard charger
- ✓ Spare battery and external charger further increases truck availability
- ✓ Suspended support wheels for more lateral stability and transport of higher loads
- ✓ Different forks available: width 540-685 mm, length up to 1.500 mm, single / twin roller
- ✓ Ergonomic tiller handler: left and right-handed users can intuitively operate all functions
- ✓ Turtle button for operation in narrow spaces

