



## ACX 10M / ACX 10E

### Manual And Electric Scissor Lift Pallet Truck Robust and Reliable Design

#### INTRODUCTION

The ACX 10M / ACX 10E is the manual and electric scissor lift pallet truck with 1000kg capacity and 800mm maximum lifting height; designed to be used to work as a lifting table, marshalling table, work bench or as a standard hand pallet truck.

#### ADVANTAGES

- Closed forktips and reinforced chassis ensure high lifetime.
- Ergonomically designed and comfortable handle with higher grip casing.
- Single cylinder for robustness and less maintenance.
- ACX 10M with quick lift function  
ACX 10E with electric lift function
- ACX 10E with built-in or external charger.

# PARAMETERS

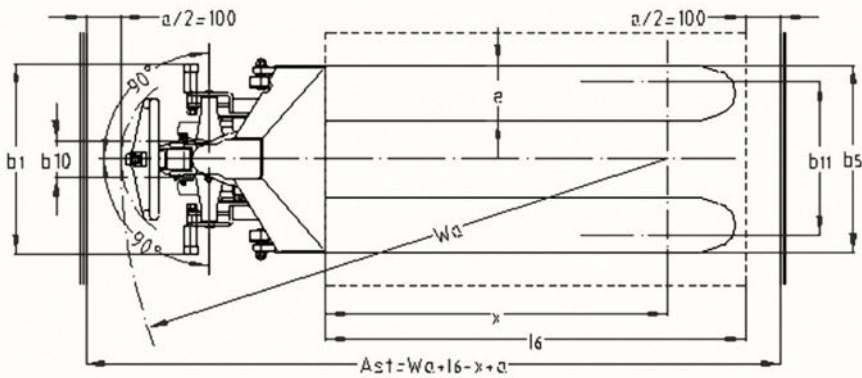
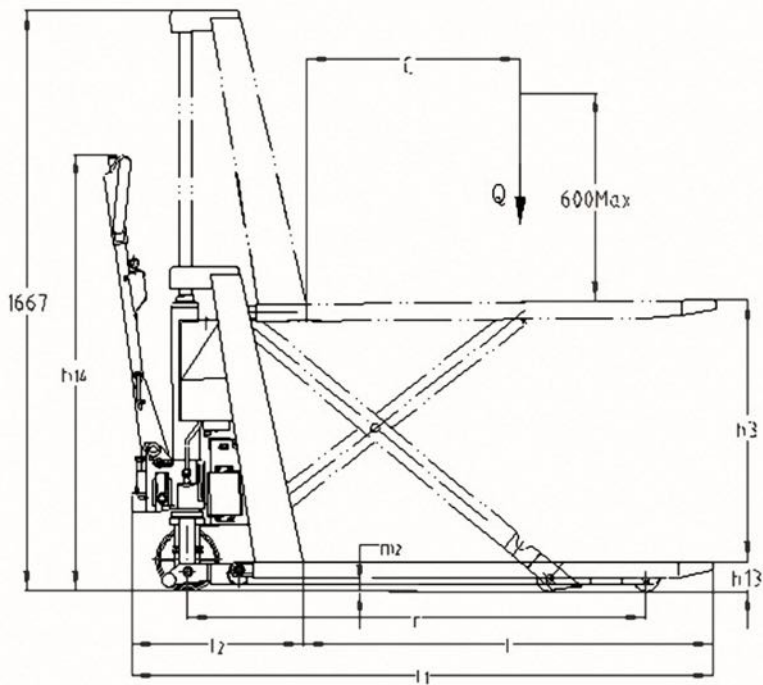

<b>Distinguishing mark</b>	1.2	Manufacturer's type designation		ACX 10E	ACX 10M
	1.3	Drive		Manual	Manual
	1.4	Operator type		Hand	Hand
	1.5	Load Capacity / rated load	Q(t)	1.0	1.0
	1.6	Load centre distance	c(mm)	600	600
	1.8	Load distance ,centre of drive axle to fork	x(mm)	978	978
	1.9	Wheelbase	Y(mm)	1310	1310
<b>Weight</b>	2.1	Service weight incl. battery(see line 6.5)	kg	152	122
	2.2	Axle loading, laden front/rear	kg	767 / 371	760 / 348
	2.3	Axle loading, unladen front/rear	kg	35 / 117	33 / 89
<b>Tyres, chassis</b>	3.1	Tyres		Polyurethane (PU)	Polyurethane (PU)
	3.2	Tyre size, front	mm	Ø180×50	Ø180×50
	3.3	Tyre size, rear	mm	Ø75× 50	Ø75× 50
	3.4	Additional wheels(dimensions)	mm	—	—
	3.5	Wheels, number front/rear(x=driven wheels)		2/ 2	2/ 2
	3.6	Tread, front	b10 (mm)	155	155
	3.7	Tread, rear	b11 (mm)	440	440
<b>Dimensions</b>	4.4	Lift (standard mast)	h3 (mm)	715	715
	4.5	Height, mast extended	h4 (mm)	1660	1660
	4.9	Height of tiller in drive position min/max	h14(mm)	1254	1240
	4.15	Height, lowered	h13 (mm)	85	85
	4.19	Overall length	l1 (mm)	1715	1725
	4.20	Length to face of forks	l2 (mm)	492	492
	4.21	Overall width	b1 (mm)	575/ 695	575/ 695
	4.22	Fork dimensions	s/e/l (mm)	45/160/1170	45/160/1170
	4.25	Distance between fork- arms	b5 (mm)	540/ 685	540/ 685
	4.32	Ground clearance, centre of wheelbase	m2 (mm)	18	18
	4.34	Aisle width for pallets 800X1200 lengthways	Ast (mm)	1986	1986
4.35	Turning radius	Wa (mm)	1564	1564	
<b>Performance data</b>	5.2	Lift speed, laden/ unladen	m/s	21/45	—
	5.3	Lowering speed, laden/ unladen	m/s	53/63	81/61
<b>Electric- Motor</b>	6.2	Lift motor rating at S3 15%	kW	0.6	—
	6.3	Battery acc. to DIN 43531/ 35/ 36 A, B, C, no		no, maintenance-free	—
	6.4	Battery voltage, nominal capacity K5	V/Ah	12V/52Ah	—
	6.5	Battery weight	kg	24	—

# KEY FEATURES



- 1 Robust chassis with reinforced forks (additional parts)



- 2 Chassis with robust upper steering bearing for less friction and steering force.



- 3 Anti-tilting skid



- 4 Reliable wiring with protection. The built-in charger makes operations more autonomy and increases the operating range.

- 5 Verified and tested structure.

- 6 Fulfilling the actual valid European standards.



- 7 ACX 10E with key switch.



- 8 Where pallets with load are more frequently lifted, the ACX 10E with the electric lifting button makes lifting easier and more comfortable.

## NOBLIFT

### NOBLELIFT CHINA

Add: No. 528, Jing Yi Road Economic Development Zone,  
Changxing zhejiang China PC: 313100  
Tel: 86-572-6210776 6210788 Fax: 86-572-6210777 6128612  
www.noblelift.com Email: info@noblelift.com

### NOBLELIFT EUROPE GMBH Spare Parts Center

Add: Borsigstrae 9D-93092 Barbing Germany  
Tel: +49 9401 607930 Fax: +49 9401 6079329  
www.noblelifteurope.com Email: inter@noblelifteurope.com

### AMERICAN NOBLELIFT CORP.

Add: 1810 S. Milliken Ave., Ontario, CA 91761, USA  
Tel: +1 909 390 6258 Fax: +1 909 390 5114  
Toll Free #: (888) 662-5354  
www.nobleliftus.com Email: info@nobleliftus.com

### SPARE PARTS CENTER

Borsigstrae 9D-93092 Barbing Germany  
Tel: +49 (0) 9401 911 330 Fax: +49 (0) 9401 911 3329  
Email: parts@noblelifteurope.com